

# HERZ Mixing valves

## Three-way and four-way

Data sheet 1 213X XX, Issue 0921

**☑ Dimensions in mm**

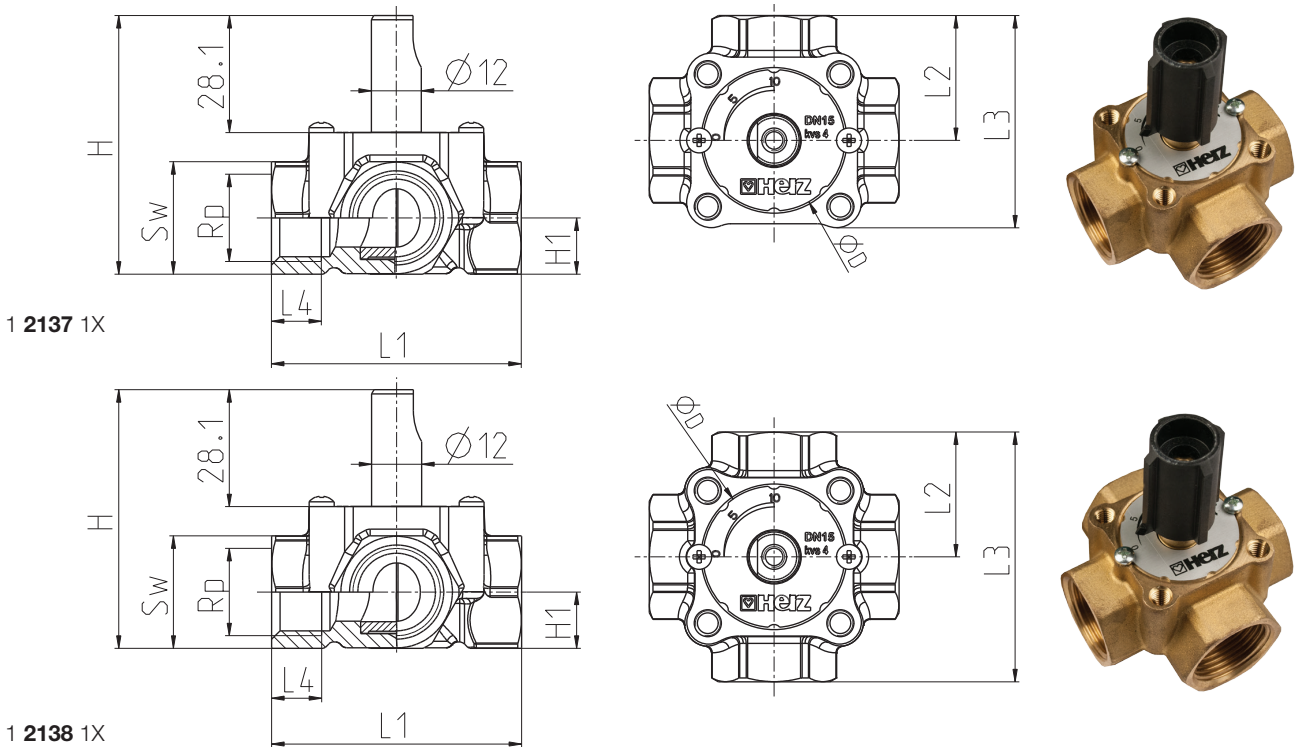

Art. Nr.	DN	kvs [m³/h]	Sw [mm]	Rp [in]	L1 [mm]	L2 [mm]	L3 [mm]	L4 [mm]	H [mm]	H1 [mm]	D [mm]	Weight [kg]	Lever
1 2137 71	15	0,4	27	½"	60	30	51	12	66,1	13,5	34	0,41	+
1 2137 31	15	0,63	27	½"	60	30	51	12	66,1	13,5	34	0,41	+
1 2137 41	15	1	27	½"	60	30	51	12	66,1	13,5	34	0,41	+
1 2137 51	15	1,6	27	½"	60	30	51	12	66,1	13,5	34	0,41	+
1 2137 61	15	2,5	27	½"	60	30	51	12	66,1	13,5	34	0,41	+
1 2137 01	15	4	27	½"	60	30	51	12	66,1	13,5	34	0,41	+
1 2137 11	15	4	27	½"	60	30	51	12	62,1	13,5	34	0,41	-
1 2137 72	20	2,5	31	¾"	64	32	53	13	66,1	15,5	34	0,44	+
1 2137 32	20	4	31	¾"	64	32	53	13	66,1	15,5	34	0,44	+
1 2137 02	20	6,3	31	¾"	64	32	53	13	66,1	15,5	34	0,44	+
1 2137 12	20	6,3	31	¾"	64	32	53	13	66,1	15,5	34	0,44	-
1 2137 73	25	6,3	39	1"	80	40	647	15	78,6	19,5	43	0,78	+
1 2137 03	25	10	39	1"	80	40	647	15	78,6	19,5	43	0,78	+
1 2137 13	25	10	39	1"	80	40	647	15	74,6	19,5	43	0,78	-
1 2137 04	32	16	49	1-¼"	90	45	713	188	89,1	26,3	43	1,15	+
1 2137 14	32	16	49	1-¼"	90	45	713	188	85,1	26,3	43	1,15	-

Art. Nr.	DN	kvs [m/h]	Sw [mm]	Rp [in]	L1 [mm]	L2 [mm]	L3 [mm]	L4 [mm]	H [mm]	H1 [mm]	D [mm]	Weight [kg]	Lever
1 2137 05	40	25	59	1-½"	110	55	88	214	100,6	30,5	61	2,41	+
1 2137 15	40	25	59	1-½"	110	55	88	214	96,6	30,5	61	2,41	-
1 2137 06	50	40	72	2"	136	68	1.055	27	113,1	37,5	61	2,573	+
1 2137 16	50	40	72	2"	136	68	1.055	27	109,1	37,5	61	2,573	-
1 2138 01	15	4	27	½"	60	30	60	12	66,1	13,5	34	0,43	+
1 2138 11	15	4	27	½"	60	30	60	12	62,1	13,5	34	0,43	-
1 2138 21	15	4	27	½"	60	30	60	12	131,6*	13,5	34	0,942*	++
1 2138 02	20	6,3	31	¾"	64	32	64	13	70,1	15,5	34	0,47	+
1 2138 12	20	6,3	31	¾"	64	32	64	13	66,1	15,5	34	0,47	-
1 2138 22	20	6,3	31	¾"	64	32	64	13	135,6*	15,5	34	0,972*	++
1 2138 03	25	10	39	1"	80	40	80	15	78,6	19,5	43	0,84	+
1 2138 13	25	10	39	1"	80	40	80	15	74,6	19,5	43	0,84	-
1 2138 23	25	10	39	1"	80	40	80	15	144,1*	19,5	43	1,44*	++
1 2138 04	32	16	49	1-¼"	90	45	90	188	89	26,3	43	1,11	+
1 2138 14	32	16	49	1-¼"	90	45	90	188	85	26,3	43	1,11	-
1 2138 24	32	16	49	1-¼"	90	45	90	188	154,6*	26,3	43	1,726*	++

- Indication: - Mixing valve without handle  
 + Mixing valve with handle 1 2100 95  
 +\* Mixing valve with drive 1 7712 63  
 \* Dimensions and weight with drive 1 7712 63

#### ☑ Components of HERZ-mixing valves

1. Valve body
2. Hatch
3. Sealing nut
4. Circlip
5. Inscription plate
6. Screw M3
7. O-ring
8. O-ring

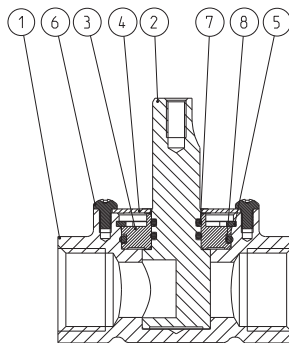

#### ☑ Construction

- Valve body: forged brass acc. to EN 12165, CW617N  
 Hatch: brass acc. to EN 12164, CW614N  
 Sealing: EPDM  
 Connection: internal threads acc. to ISO 7-1

#### ☑ Operating data

- Maximum temperature: 120°C  
 Nominal pressure: PN 10  
 Permanent temperature load: -10°C...120°C  
 Torque (at PN 10): ≤ 5 Nm  
 Angle of working stroke (turn): 90°  
 Medium: Heating water quality according ÖNORM H5195 or VDI-Standard 2035. The use of ethylene or propylene glycol in a mixing ratio 25- 50% is allowed.

### ☑ Application

HERZ-mixing valve is used as actuating element in heating and cooling systems for continuous control or regulation of the medium temperature. With a corresponding motor drive it is used as a control device with linear, proportional or quadratic characteristics. Three-way mixing valve can be used as a mixing or flow-diverting valve. Four-way mixing valves have a dual function of mixing, namely, they mix a share of hot water from the boiler with the return water. This results in a higher return water temperature, reducing the risk of corrosion and ensuring longer service life for the boiler.

### ☑ Assembly

HERZ-mixing valve can be mounted in any position. As part of a motor drive, the assembly in hanging position is not recommended due to the possibility of water breaking into a motor drive. The three-way mixing valve is installed in pipe systems with the help of connectors depending on the application (mixing or distributing functions).

### ☑ Maintenance instructions

If the product is used properly, no special maintenance is required in normal operation. The ingress of condensate, dripping water etc. into the drive should be prevented. Repairs on the device must be carried out by authorized persons only.

### ☑ Disposal instructions

If the product is used properly, no special maintenance is required in normal operation. The ingress of condensate, dripping water etc. into the drive should be prevented. Repairs on the device must be carried out by authorized persons only.

### ☑ Characteristic curves of three-way valve

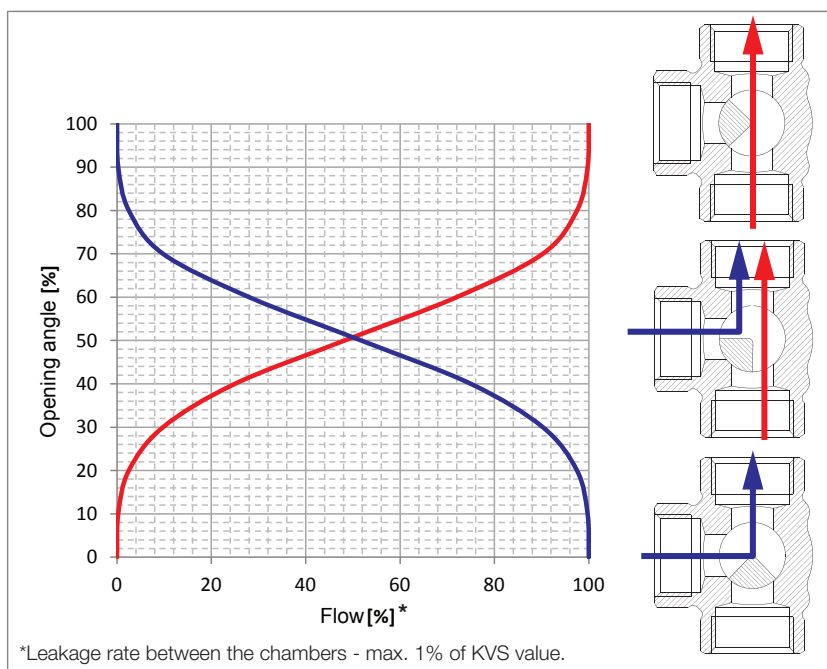

### ☑ 3-Point Actuator (1 7712 63)

The actuator can be operated by 3-point and open-close control (see diagram). The mounting position in relation to the ball valve can be selected in 90° steps. The actuator is automatically disconnected when the end stops are reached. The actuator can be mounted in any position except with its head down. Two-piece body made of self-extinguishing plastic, the lower part is black and upper part is red. Straightforward direct mounting on the mixing ball valve with a screw. The screw is supplied with an actuator.

#### Manual operation possible by lever:

Press for temporary disengagement, permanent gearing disengagement by rotary switch on the housing cover to the manual position.

#### Safety note:

The actuator may only be opened at the factory. It contains no components which can be replaced or repaired by the user.

**Technical data**

Nominal voltage	AC 230 V 50 / 60 Hz
Power supply range	AC 198 ... 264 V
Dimensioning	3,5 VA
Power consumption	3,5 W
Auxiliary switch	1 x EPU 5 (1) A, AC 250 V
Switching point	adjustable 0 ... 100%
Manual operation	Temporary and permanent disengagement of the gearing latch
Torque	min. 10 Nm (at nominal voltage)
Angle of rotation	90°
Running time	140 s
Sound power level	max. 35 dB(A)
Position indication	Scale 0 ... 10
Protection class	II (totally insulated)
Degree of protection	IP40
Ambient temperature range	0 ... + 50 °C (duty cycle 140/35 s)
Media temperature	+ 5 ... + 120 °C (ball valve)
Non-operating temperature	- 30 ... + 80 °C
Humidity test	according to EN 60730-1
EMC	CE according to 89/336/EWG
LV directive	CE according to 73/23/EWG
Mode of operation	Typ 1.B (EN 60730-1)
Maintenance	Maintenance-free

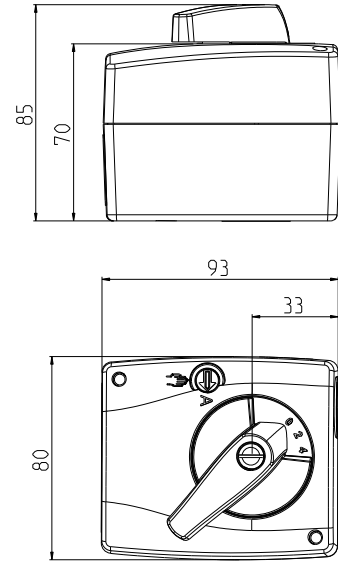

**Technical**

**3-Point Control**

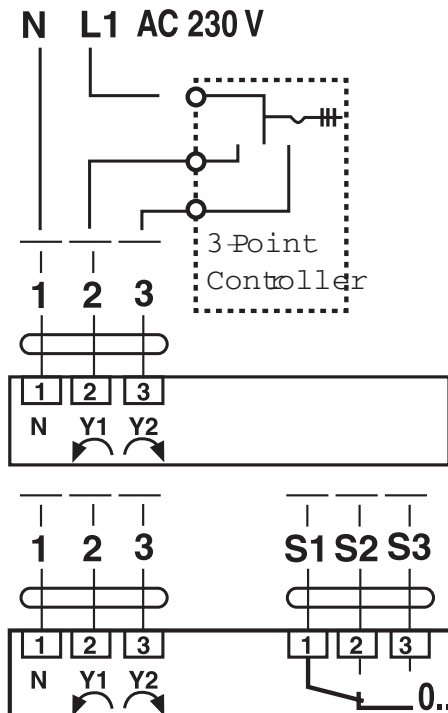

**Open-Close Control**

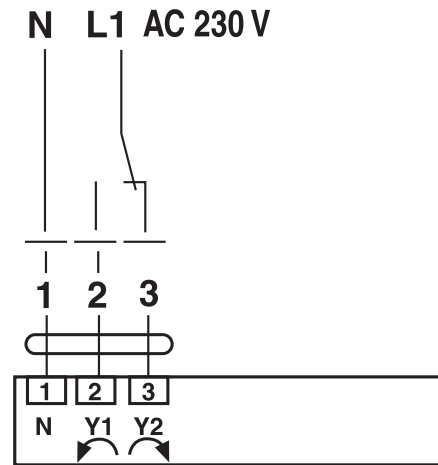

Funktion

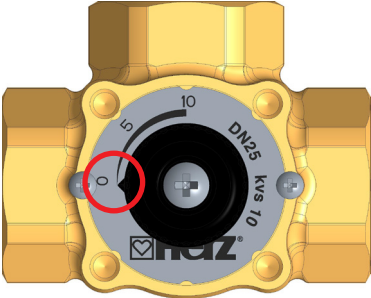
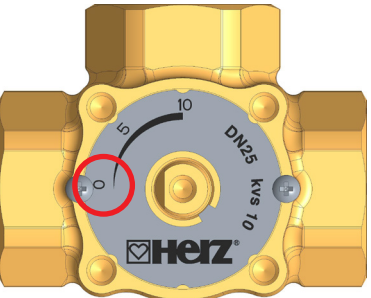
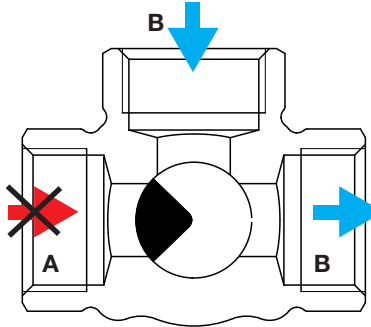
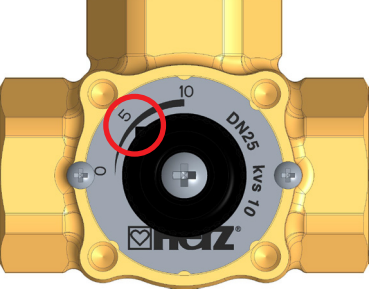
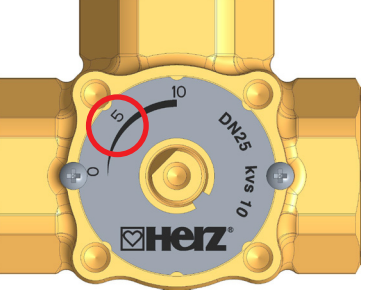
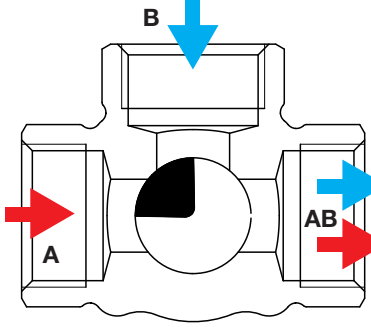
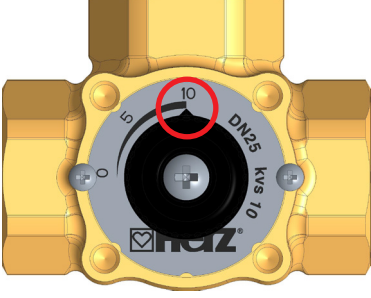
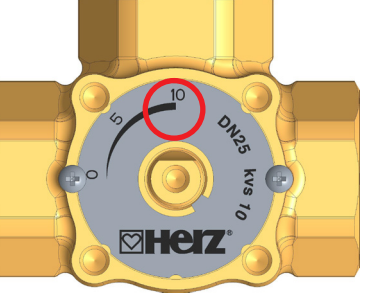
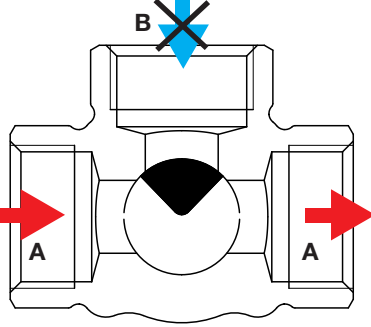
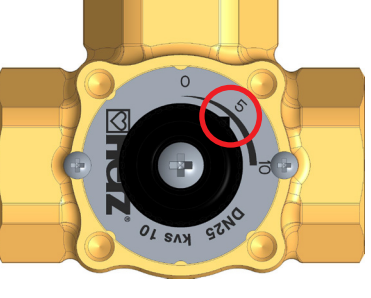
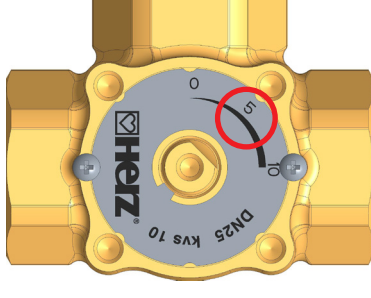
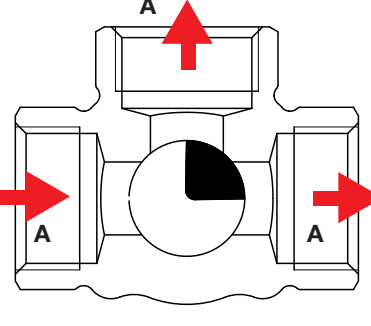
3-Way mixing valve with handle	3-Way mixing valve without handle	Flow direction*
		
		
		
		

\*Leakage rate between the chambers - max. 1% of Kvs value.

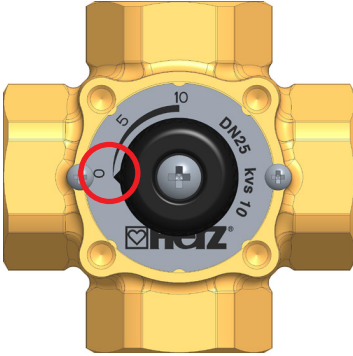
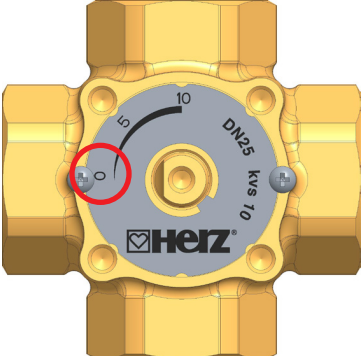
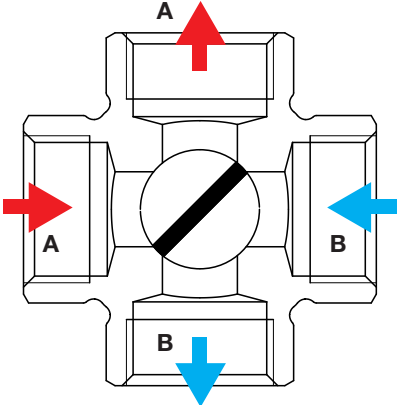
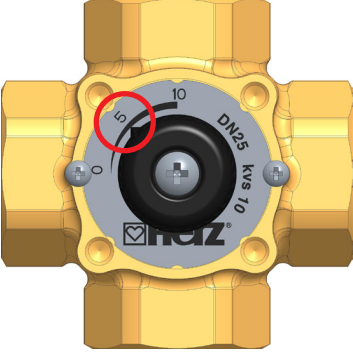
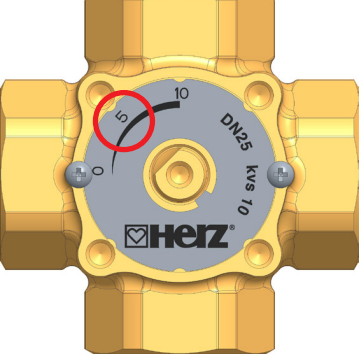
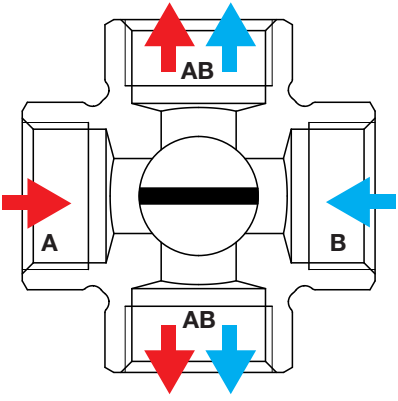
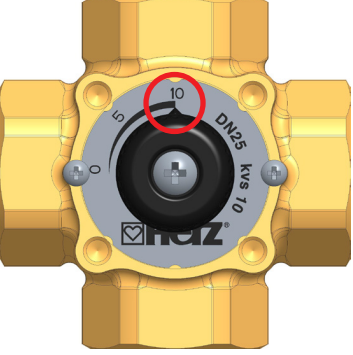
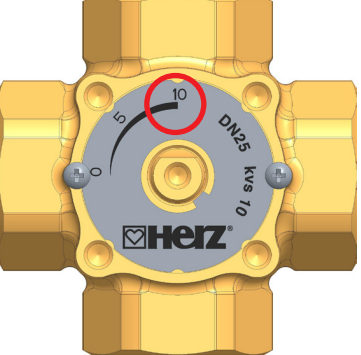
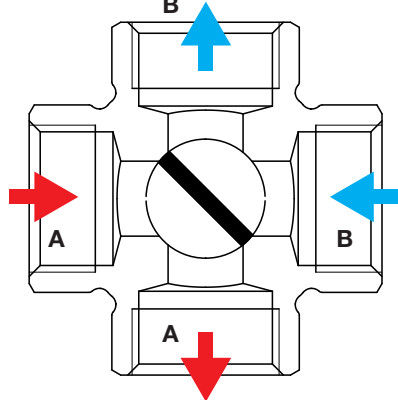
4-Way mixing valve with handle	4-Way mixing valve without handle	Flow direction*
		
		
		

\*Leakage rate between the chambers - max. 1% of Kvs value.

☑ Pressure drop curves of three-way valves

**DN 15**

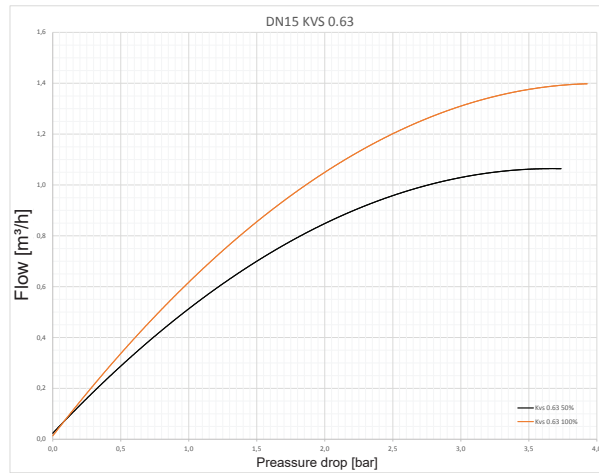

**1 2137 31**

**DN 15**

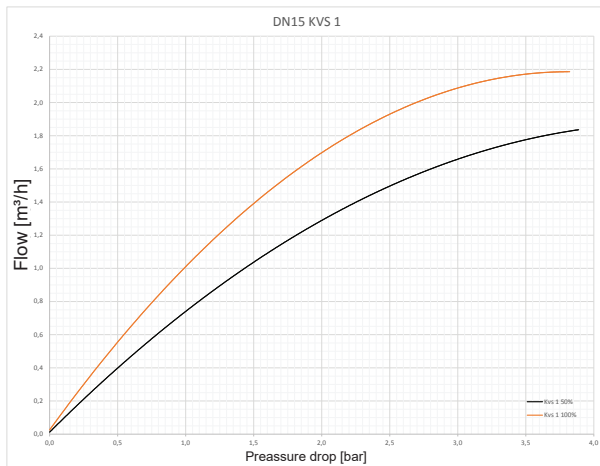

**1 2137 41**

**DN 15**

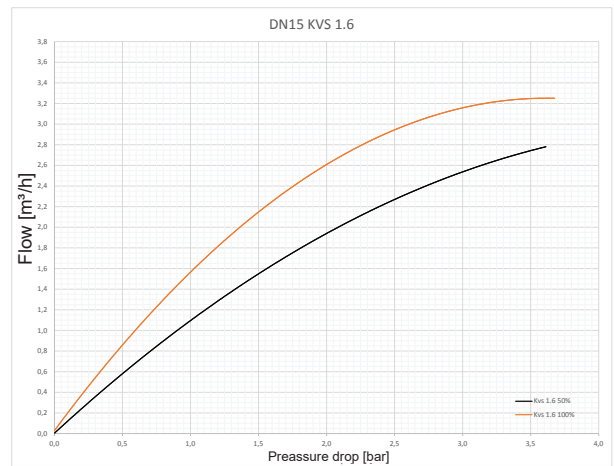

**1 2137 51**

**DN 15**

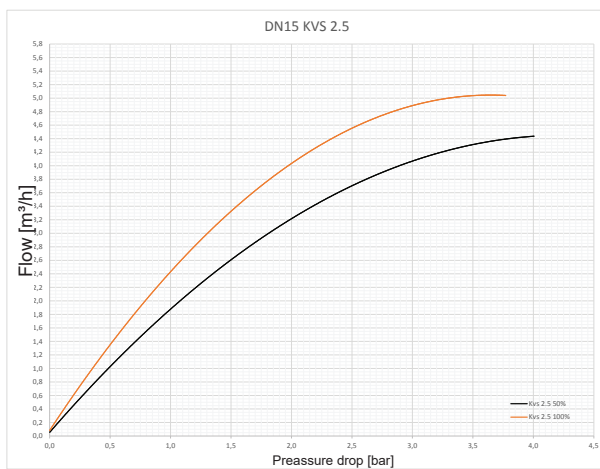

**1 2137 61**

**DN 15**

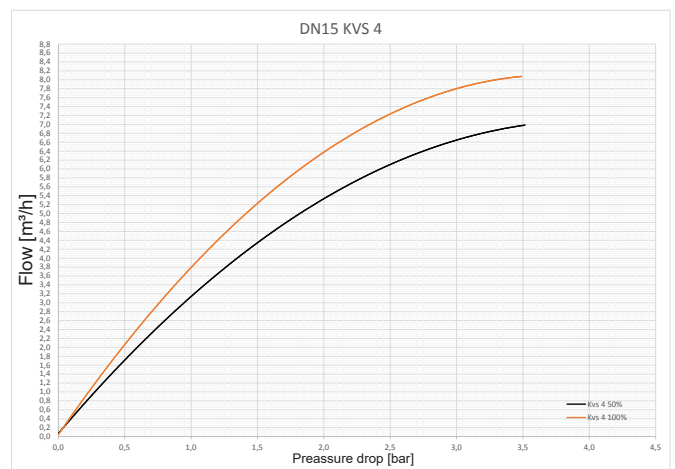

**1 2137 11**



**DN 20**

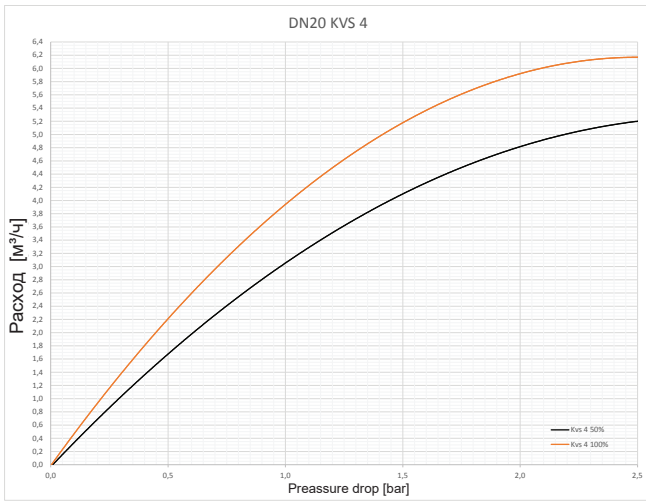

**1 2137 32**

**DN 20**

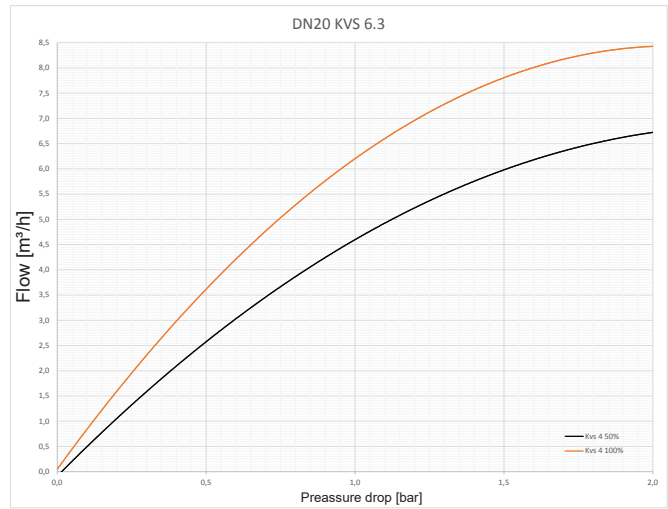

**1 2137 12**

**DN 25**

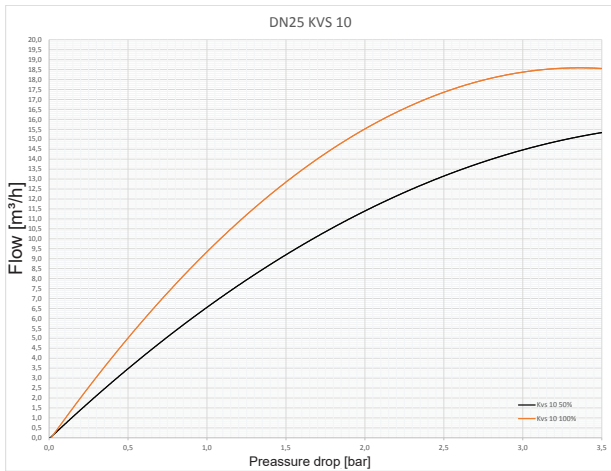

**1 2137 13**

**DN 32**

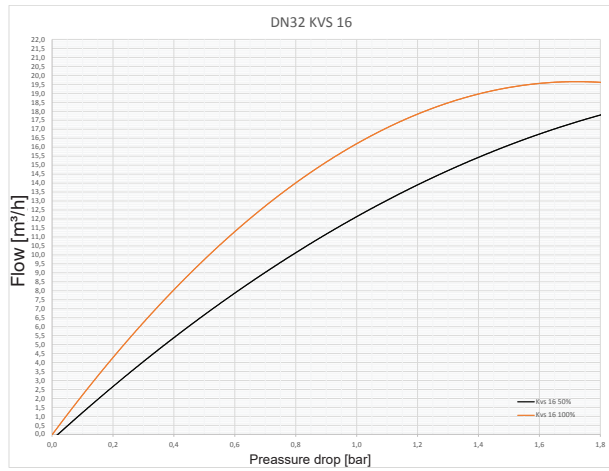

**1 2137 14**

**DN 40**

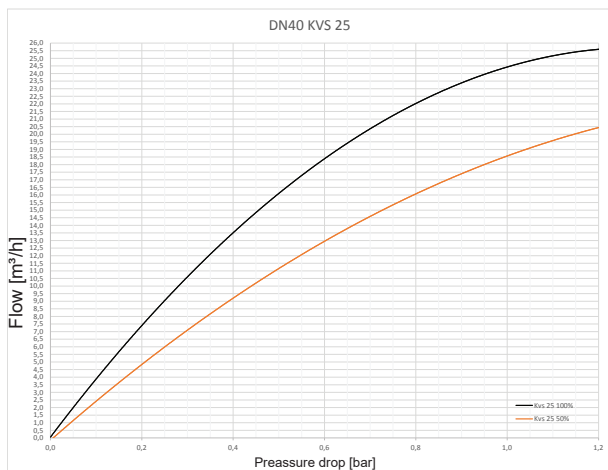

**1 2137 15**

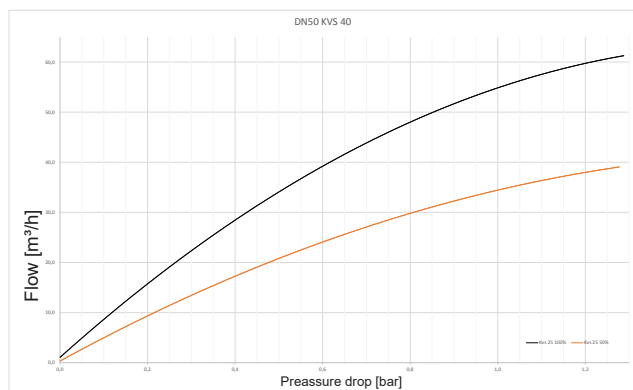

**DN 50**



**1 2137 16**

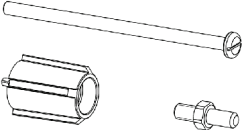
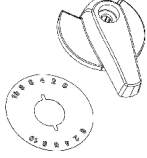
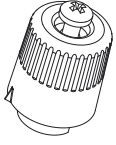

Spare parts

Illustration	Description	Item number	Compatible with
	<p><b>Montage set for actuator</b> 1 7712 63</p>	<p>1 7712 67</p>	<p>1 2137 XX 1 2138 XX</p>
	<p><b>Handle and scale for actuator</b> 1 7712 63</p>	<p>1 7781 03</p>	<p>1 2137 2X 1 2138 2X</p>
	<p><b>Handle for mixing valve</b></p>	<p>1 2100 95</p>	<p>1 2137 XX 1 2138 XX</p>
	<p><b>HERZ rotary drive for HERZ 2137, 230 V/AC</b></p>	<p>1 7712 25</p>	<p>1 2137 XX 1 2138 XX</p>
	<p><b>HERZ rotary drive for HERZ 2137, 24 V/AC/DC</b></p>	<p>1 7712 27</p>	<p>1 2137 XX 1 2138 XX</p>

## ☑ Examples of usage

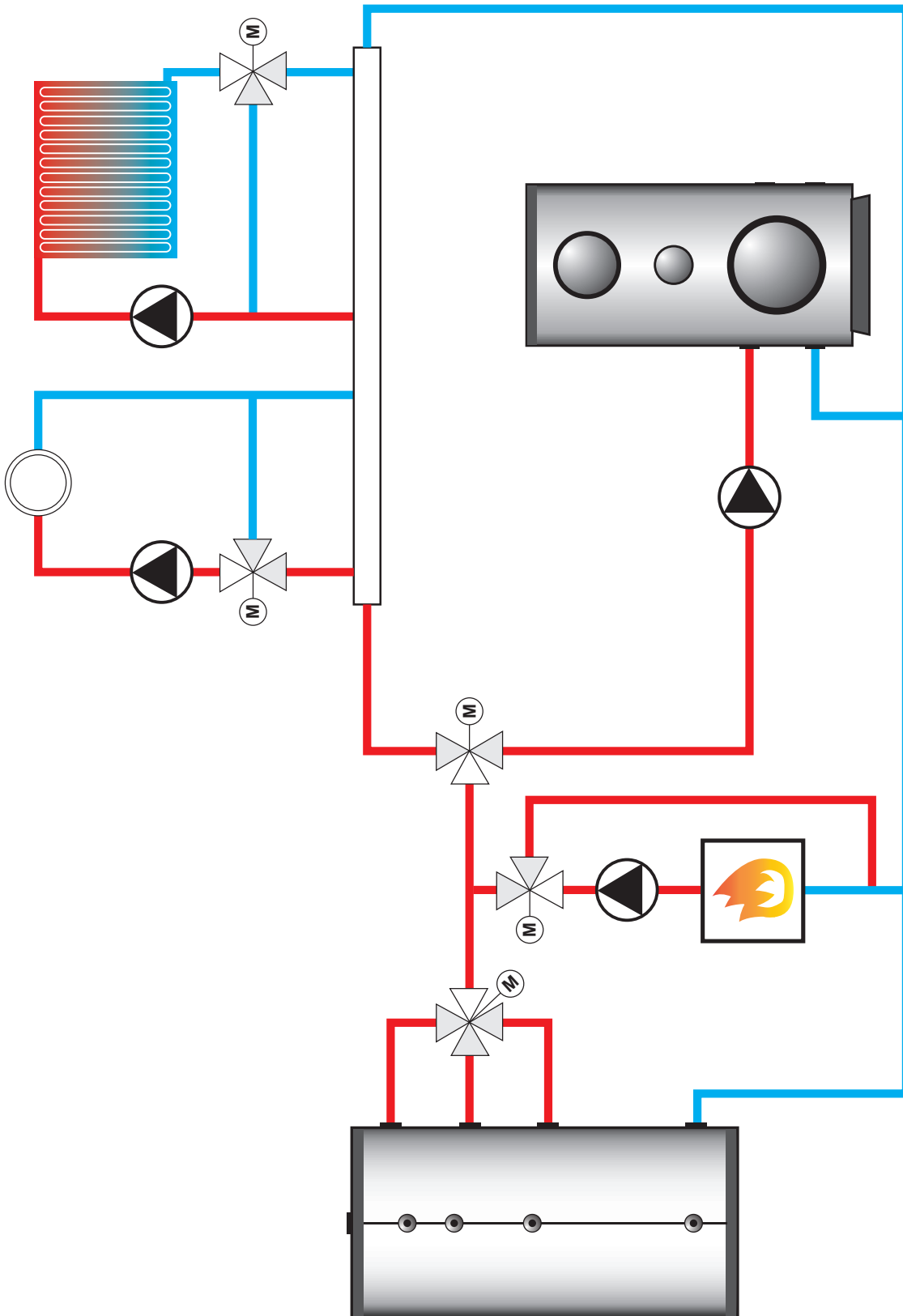

Please note: All specifications and information within this document are reflecting the information available at the time of going to print and meant for informational purpose only. Herz Armaturen reserves the right to modify and change products as well as its technical specifications and/or its function according to technological progress and requirements. All diagrams are indicative in nature and do not to be complete. It is understood that all images of Herz products are symbolic representations and therefore may visually differ from the actual product. Colours may differ due to printing technology used. In case of any further questions don't hesitate to contact your closest HERZ Branch-Office.